

## Advantage Framed Door and Drawer Front Specifications

---

The Advantage Framed RTA Cabinet Systems program offers a wide variety of Conestoga's 3/4" thick Custom door and drawer front designs. From transitional to traditional to contemporary and beyond, hundreds of design options are available. The full array of door and drawer front designs as well as related details and options can be found in our Custom Product Manual.

- **Door Designs:** Any of Conestoga's 3/4" thick doors and drawer front designs are available with the Advantage Framed RTA cabinet program. This includes eligible framing bead, panel raise and edge profile options available with each design.
- **Door Species:** The standard species for the Advantage Framed RTA program include Cherry, Hard Maple, Soft Maple, and Red Oak. With the exception of Soft Maple, these species can be ordered in Premium, Standard or Rustic Knotty grade lumber. Soft Maple is available in Standard grade only. For painted finishes, doors and drawer fronts should be ordered in Hard or Soft Maple. Additional species are available, but components such as doors, drawer fronts, front frames, and mouldings must be ordered separately from Cabinet Systems units. 1/4" plywood end skins for painting are available in Cherry, Hard Maple, and Red Oak.
- **Door Thickness:** The Advantage Framed RTA program can be paired with any of Conestoga's 3/4" thick door designs. Doors thicker than 3/4" are not compatible with the standard Blum COMPACT hinge offering, and are not eligible to be ordered in conjunction with the Advantage Cabinet Systems program. If doors and drawer fronts thicker than 3/4" are desired, Conestoga will configure and size the doors for the appropriate cabinets, but customers must omit the Blum COMPACT hinges as they are engineered for 3/4" thick doors. Customers are responsible for supplying their own 1" hinges.
- **Door Overlays:** The Advantage Framed RTA program offers four standard overlays and inset doors. Standard overlays include 1/4", 1/2", 1-1/4" and 1-3/8". When 1-1/4" and 1-3/8" overlays are selected, extended stiles or loose filler strips may be required for applications where cabinets are installed adjacent to a wall or tall cabinet to ensure adequate clearance. The necessity for extended stiles or loose filler strips is determined by the type of hinge being used. Corner cabinets are provided with special hinging.
- **Multi-Panel Doors:** Tall multi-panel doors manufactured with upper and lower panels have the option of different designs for each panel. For instance, if the wall cabinet doors are an arch design and base cabinet doors are a square design, the upper panel of the tall door can match the arch of the wall cabinets, while the lower panel can match the base cabinets. If not specified, both the upper and lower panels will be manufactured with square panels.
- **Butt Door Cabinets:** All butt door cabinet doors receive an edge profile on the sides and have a 1/8" gap between doors. Butt doors with a C-edge profile are paired and profiled on three sides with a C-2 edge profile on the fourth side.
- **Overlay Illustrations:** Diagrams showing the different overlays and spacing between doors and the distance between the door's edge and the exterior edge of the front frame can be seen on the following page.

## Overlay Diagrams (w/center stile)

### 1/4" Overlay

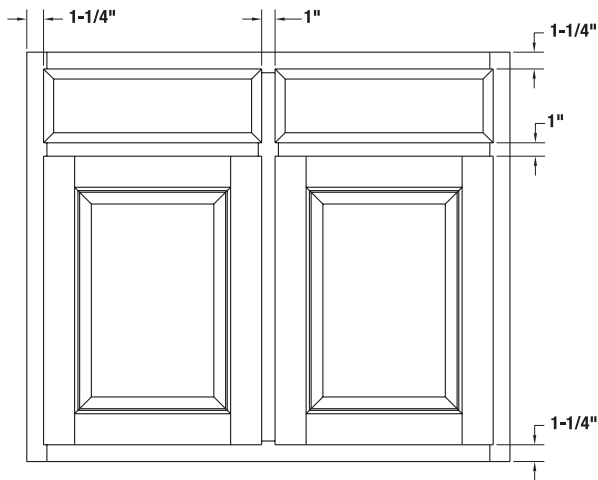
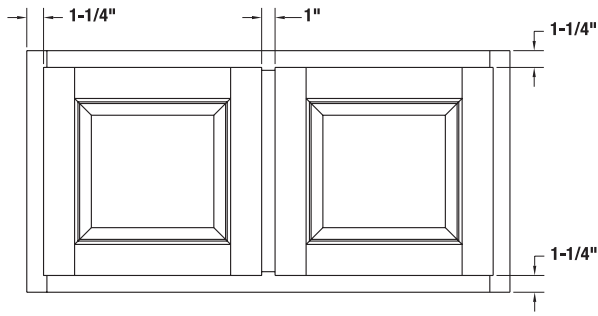

### 1/2" Overlay

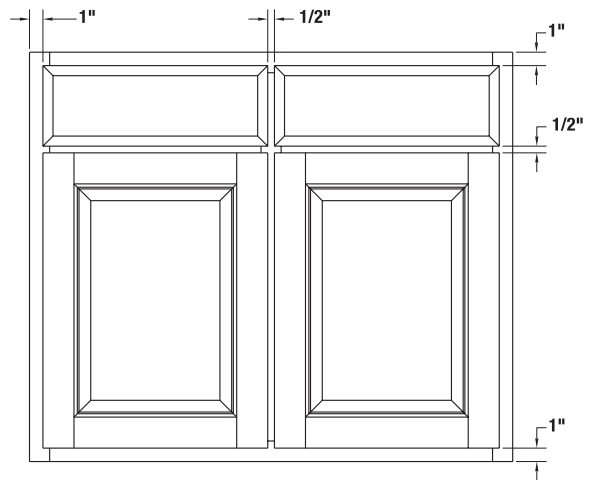
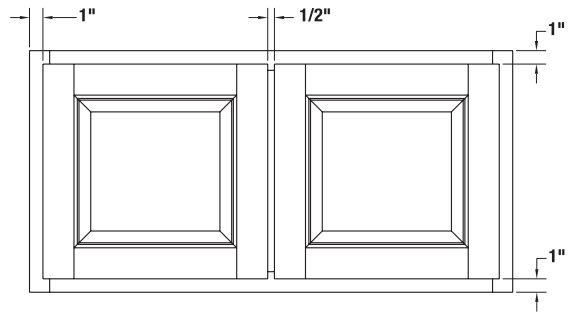

### 1-1/4" Overlay

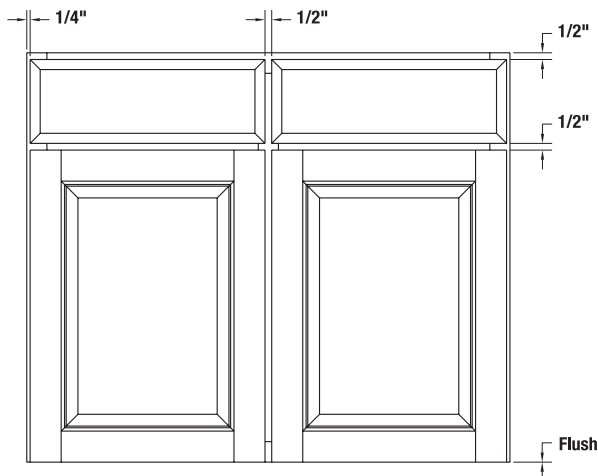
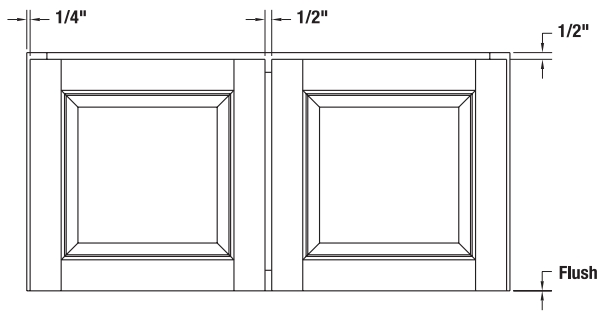

### 1-3/8" Overlay

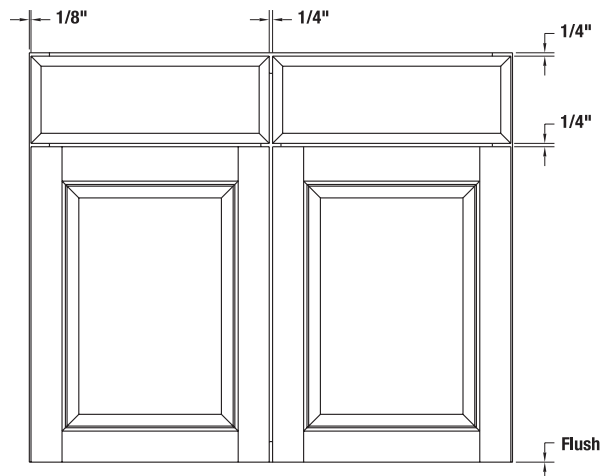
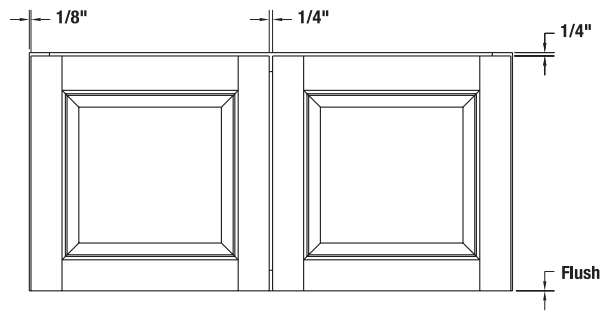

## Inset Door and Drawer Information

- Front frames ordered with inset doors and drawer fronts will be pre-fit to the opening size. A 3/32" margin will be used on all sides for single doors and drawer fronts and between butt door pairs.
- The following edge profile options are recommended for use with inset doors and drawer fronts. These edges have a 5 degree back bevel edge to ensure sufficient door clearance. Machine Edge is available upon request at no additional upcharge.

### Standard Lip Options

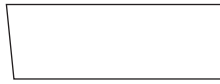

L-253

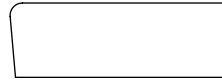

L-686

### Design Exceptions

- The following door and drawer front designs are not available for inset applications due to their unique design characteristics: 1-1/8" Sandwiched Drawer Front, #10 Drawer Front, 10141 Drawer Front, Alexandria, Aspen, AspenPP, Astoria, Boulder, BoulderPP, CRP-1420, CRP-10191, CRP-10318, CRP-10334, CRP-10827, CRP-10875, CRP-10946, Fairhaven, Fargo, FargoPP, Flush Batten, Hastings, Juno, Keystone Drawer Front, LaSalle, Marcel Drawer Front, Omaha, OmahaPP, Prestige, Rothbury, Rothsford, Savoy, Topeka, TopekPP, TW-10827, Venus and Venus78.
- Alternative Material doors and drawer fronts are not available for inset applications including Allure DLV, Intrigue TTS, Strata TTS, Vogue TTS, Synchronicity High Gloss and Super Matte products.
- The following standard edge profile options are available for inset applications: L-253 and L-686. Premium edge profiles: L-304 and L-996 upcharge applies.
- Front frame openings with trimmable inserts are not available beaded.
- Inset and beaded front frames that are ordered with Colourtones and glazes will receive the same hand glazed finishes as doors. Case parts will not receive a hand wiped glaze. Cabinet Systems parts that are ordered with select Colourtone and glaze combinations will be finished with Colourtones that have been tinted to match one of the select Colourtone and glaze combination\*.

### Inset Option with Miter Designs Not Recommended

Only miter door designs with edge profile options are available with the inset option; however, miter designs are not recommended with the inset option. The following issues are associated with inset miter designs, and will not be considered defective:

- **Miter joint lines may not intersect door corner after pre-fit sanding.** This is not considered a defect as it is a necessary part of the pre-fit process to ensure the proper fit within the frame openings. This condition may not be pleasing to some customers.
- **Panel expansion caused by high humidity may cause miter doors to bind inside frame openings.** Although Conestoga's miter door joint construction is one of the most durable in the industry, high humidity will cause solid wood center panels to expand in width. This pressure can result in framing pushing outward and creating a "barrel" effect where the framing rubs against the front frame.
- If a miter design is selected, it is highly recommended that doors and drawer fronts be manufactured as 5-piece MDF, Hybrid products with MDF center panels or with plywood center panels. These materials will reduce the likelihood of product expansion and binding of inset doors within the front frame. While reducing the possibility of binding, expansion of solid wood framing can still occur and will not be considered defective.

\*See Section 12 Finishing Program for select Colourtone and glaze combinations.

### Inset Door Diagram (w/center stile)

